

Sliding Compound Miter Saw Notes

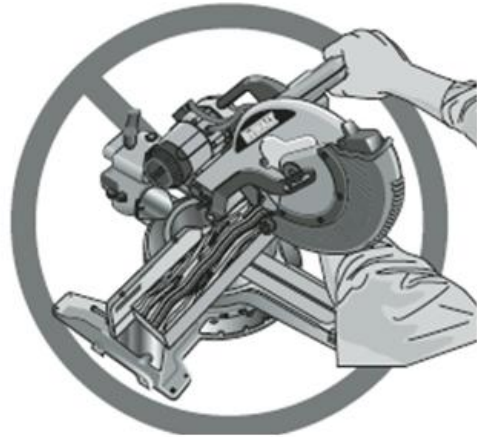

- **Be Safe:** Always wear _____ when working with any machinery in the shop!
- **Full Speed:** Allow the blade to reach _____ before making a cut.
- **Slide feature:** If the slide feature is _____, ensure the head is pushed back all the way, and the rail lock tightened. This prevents the saw from _____ as the cut is made.
- **Full Stop:** Let the blade come to a _____ before lifting the blade from the cut.
- **Proper cutting:** When cutting anything larger than 8" wide, use an _____-_____ motion. Start the saw, pull toward you, lower to cut, slowly push back to complete the cut.
- **Do not!** Do not allow the _____ to contact the workpiece as you pull it out. This will cause the saw to _____ at you.

- **6"** Never allow hands to come _____ than 6" to the blade!
- **Hold tight!** Hold workpiece firmly _____ the table and fence.

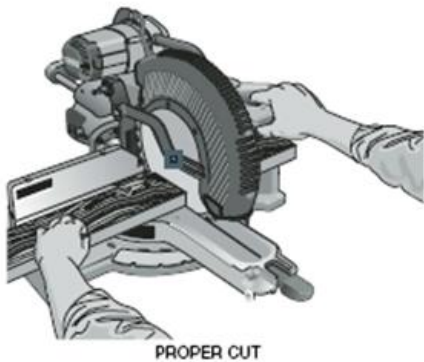

**Improper cut! Never
Cross-arm cut!!**

FIG. 21

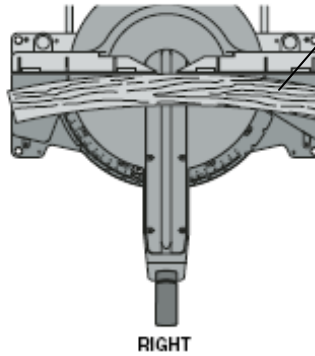

Since we use the sliding compound miter saw to do a lot of "rough cutting" you may frequently have a warped board you need to trim. ALWAYS cut like this illustration!

FIG. 22

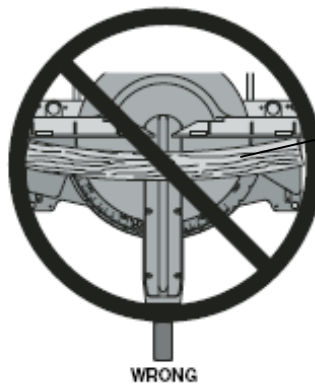

Making a cut like this will cause the blade to bind and a kickback of the entire blade assembly! Never cut a warped board like this!!!